

The background of the page is a photograph of a modern classroom or lecture hall. The room has a white grid ceiling with recessed circular lights. Rows of grey chairs and long tables are arranged in the room. The walls are white and grey. A green curved graphic element is overlaid on the bottom half of the page.

CB-H24

1-Way and 2-Way Active Chilled Beams

CB-H24 OVERVIEW

The Carson Solutions 24 inch wide comes standard with a horizontal hydronic heat exchanger and linear discharge slots. The (CB-H24) active chilled beam is designed to provide high cooling and heating capacities by conditioning the rooms air while simultaneously supplying a fresh conditioned, code required, primary air to the occupied area. Hydronic heating or cooling where the hydronic systems are integrated with the primary ventilation system. The central Air Handling Unit (AHU) or Dedicated Outdoor Air Supply (DOAS), supplies the chilled beam with tempered and dehumidified conditioned primary air to maintain the required ventilation and humidity control of the space while addressing the latent load. The remaining space sensible loads are addressed with the integrated hydronic heat exchanger inside the chilled beam housing. The use of linear induction nozzles within the chilled beam induces the room's return-air through the beam's face grill, then across a horizontally mounted hydronic heat exchanger which spans the full length of the beam housing.

CB-H24 OVERVIEW (CONTINUED)

During the induction process, the nozzles also discharge the fresh conditioned primary air, delivered by the AHU or DOAS unit, at selected velocities causing the induced room air to be pulled into the beam's mixing chamber and redistributed into the space by the beam's integrated linear discharge slots. Both the induced room air and the supplied primary air mixes and delivers the combined airstreams into the occupied zone. This process increases efficiency which maximizes cooling and heating capacity per unit of mix air flow streams to deliver premium performance and thermal comfort. The air delivery process from the chilled beam has inherent characteristics related to temperature, velocity, and airflow throw. Chilled beams airflow throw characteristics relates to the velocity and temperature differentials that diminish at a rate that is directly proportional to the distance the air has traveled within the space. It is important to understand the room and occupant load and the space layout to properly layout desired chilled beams.



Chilled beam technology has been proven to reduce energy consumption and operating cost associated with removal of space sensible thermal loads while simultaneously supplying fresh conditioned air to the occupied area to maintain the proper indoor air quality (IAQ). By handling the sensible load within the space, chilled beam technology provides a way to decrease the volume of supply air required to the minimum ventilation rate. Further cost savings is recognized due to the reduction in size and capacity of the AHU or DOAS equipment and other construction materials. Installed and equipment costs are also commonly reduced in chilled beam applications due to reduced code required primary air volume needed to operate each chilled beam. Reduced volume of primary air allows for smaller duct work sizing and the addition of the chilled beam low profile design makes it an ideal application solution for buildings with low ceiling heights. Utilizing chilled beams with a constant volume (DOAS) unit that delivers required minimum ventilation rate airflow may decrease the overall amount of outdoor air being supplied in which decreases the energy output required to treat that air. Applications with low latent cooling loads could use 100% outdoor air allowing for use of a DOAS with energy recovery further reducing total system energy consumption.

CB-H24 INDOOR AIR QUALITY & SYSTEM EFFICIENCY

Chilled beams are applied for many reasons: Acoustics, thermal comfort, and maintenance but two key benefits chilled beams help deliver to system operation are improved Indoor Air Quality (IAQ) and improved energy efficiency when designed and applied appropriately.

Increased awareness of IAQ is prevalent with how it directly affects the presence of airborne contaminants. ASHRAE 62.1 outlines the industry standards for ventilation and acceptable indoor air quality. The combination of a DOAS based air handler providing the known, quantifiable amount of outside air together with chilled beams can help ensure spaces are receiving the prescribe amount of OA for healthy environments.

Additionally, increased system efficiencies can be recognized by the integration of this DOAS-chilled beam system approach. Proper sizing of the DOAS unit to handle the latent loads of the ventilation air and the occupants, truly decouples the moisture loads from the temperature or sensible loads of the space, thereby making the system more efficient, as the chilled beams only need to be sized for the sensible load.

The predominant efficiencies of a chilled beam system reside in the fact that beams are a hydronic method of treating the space versus an "all-air" method. Water is denser and a more efficient medium than air for addressing space loads.



Additionally, the energy required to move water via pump energy is more efficient than fan power to move air, up to seven times more efficient.

National and local energy codes are ever evolving and placing more stringent requirements for higher operating efficiencies. ASHRAE 90.1 outlines the energy standard for most commercial building types and local codes should be reviewed carefully. The integration of DOAS-chilled beam into designs can help Engineers deliver proven efficiencies for the Owners.

An increasing trend in HVAC mechanical designs is the national and local presence of decarbonization or electrification into component selection. By selecting an appropriate designed DOAS unit together with a geothermal or electric based hydronic cooling and heating plant, the designers can check the electrification box for their needs. When using the chilled beam as a terminal device, it is a perfect complement to this system design.



CB-H24 THERMAL COMFORT

With the Carson Solutions chilled beam offering occupants will notice within a space that is conditioned with chilled beams an overall increase in thermal comfort beyond that which is achievable through traditional systems. This is due to the chilled beam's inherent design characteristics which results in a decrease in noise, draft conditions, and temperature irregularities. Chilled beams are typically operated with sound levels under 20 NC which is lower when compared to traditional overhead air distribution systems which can produce sound levels in the range of NC 35-40. Chilled beams deliver air at lower velocity than standard overhead systems which reduces cold/hot draft conditions. This also results in efficient and effective mixing of room air and primary air supply which creates comfortable and consistent room temperatures. Occupant comfort should be a primary concern when evaluating airflow and air distribution requirements similar to traditional overhead air distribution systems. The guidelines in the ASHRAE Standard 55 must be followed as it relates to temperatures and velocities within the occupied zone that have a direct impact on occupant comfort.

CB-H24 DESIGN FEATURES

The Carson Solutions CB-H24 can be supplied with either 1-way or 2-way air throw patterns to provide optimal thermal comfort. Currently available are four types of heat exchange coils, a two-pipe system for cooling or heating using a changeover valve and a four-pipe system which enables any room to be cooled or heated independently. Both two and four-piped coils can be manufactured in a single or dual circuit arrangement depending on performance needs. The CB-H24 chilled beam can also be selected with four nozzle configurations depending on induction ratios needed to meet space load requirements. Four variable inlet sizes are selectable based upon optional chilled beam lengths from 2-8ft. Integration into grid style suspended ceiling systems can easily be accommodated with our three boarder style options along with an exposed mounting beam for open room or hallway areas. Water entering the heat exchange coils should still be maintained at or above the dew point temperature of the space to prevent condensation.

CB-H24 CONSTRUCTION DESIGN FEATURES

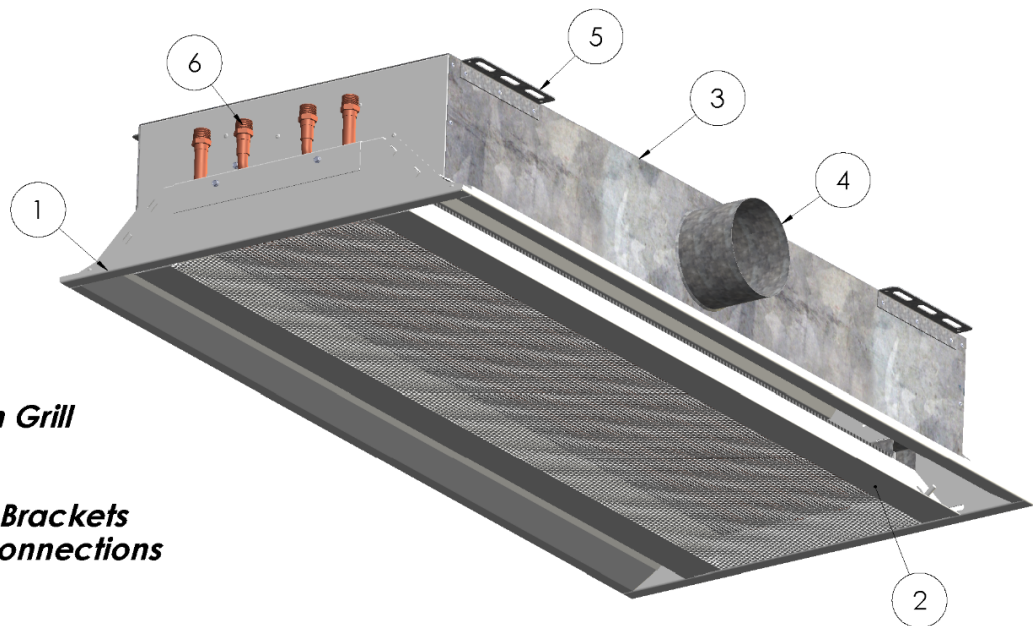

- 1. Beam Casing**
- 2. Induction Return Grill**
- 3. Beam Plenum**
- 4. Primary Air Inlet**
- 5. Fixed Mounting Brackets**
- 6. Hydronic Coil Connections**



CB-H24 PERFORMANCE CHARACTERISTICS

Due to the energy density of water compared to air, on average it takes about 1/10 the energy to move the same amount of thermal energy with hydronic transfer than it does with air transfer through ductwork. Chilled beams achieve a higher level of mixed air distribution within a space. Additionally, when the primary air is kept to a minimum chilled beams offer quiet operation and a higher levels of occupant thermal comfort. Primary airflow supply ranges from 20-360 cfm. in which delivers 2,000-13,000 btuh/ft. of chilled beam total sensible capacity. Resulting sound levels are determined based upon the selected induction ratio and the beam's available primary air inlet sizes in order to deliver low NC15-40 acoustic levels. Although uncommon, concerns about the potential for condensation, it is common for the designer to explore using a condensate sensor as a safety feature in the event the moisture load is too great.

Performance Range	Total Sensible Cooling (Btu/h/ft)	Total Sensible Heating (Btu/h/ft)	Sound Pressure Level NC
CB-H24 1-Way Discharge	400 - 1,300	550 - 1,750	15 - 40
CB-H24 2-Way Discharge	300 - 1,600	500 - 2,000	

Design Features	Standard Capacity	High Capacity
Primary Airflow	5 – 15 cfm/ft. (1-Way Discharge) 5 – 30 cfm/ft. (2-Way Discharge)	
Cooling Capacity	Up to 10,000 Btu/h	Up to 13,000 Btu/h
Heating Capacity	Up to 10,000 Btu/h	Up to 12,400 Btu/h
Cooling Room Air Temp	73° - 77°F	
Heating Room Air Temp	68° - 72°F	
Primary Supply Air Temp	55° - 66°F	
EWT Cooling	1-2°F Over Space Dew Point	
EWT Heating	90 – 140°F	
Water ΔT Cooling	2 – 6°F	
Water ΔT Heating	9 – 18°F	
Water Flow Rate	min: 0.25 gpm max: 2.5 gpm	
Water ΔP	0 – 10 ft	
Air ΔP	0.2 – 0.8 in	



CB-H24 APPLICATIONS

The Carson Solutions CB-H24 is a suitable terminal device solution in a wide variety of applications such as: office buildings, K-12 and Higher Education environments, and varying laboratory spaces. Office building applications are typically installed in open office areas, private offices, conference rooms, hallways which can be utilized in both interior and perimeter zones. For schools and universities, active chilled beams can be applied in multiple spaces including libraries, classrooms, offices, lecture halls, and labs. In lab spaces applications, beams are typically applied in load driven environments. Healthcare facilities commonly apply chilled beams in patient rooms and administrative areas.

CB-H24 OPERATION AND MAINTENANCE

The Carson Solutions chilled beam operation and maintenance is relative to almost none because the supply air is supplied by fans upstream of each chilled beam. Within the chilled beam there are no moving parts that will be a maintenance issue for replacing parts. Typically, all the maintenance required for the beam itself is “as needed” vacuuming of the coil, which can be accessed by unlocking and swinging down the hinged perforated grill. This also helps to the service costs are minimal. Replacement filters are not required for individual beams because air filtration occurs upstream within the DOAS unit. Proper water treatment should be addressed to prevent corrosion within the hydronic water coil. The chilled beam hydronic coil can be drained with the supplied drain valve in case of an issue within the space.

DIMENSIONAL DATA

Side Inlet - Coil Mount Handings

Left Coil Handing/
Pipes Left of Inlet

$W = 23\frac{3}{4}"$

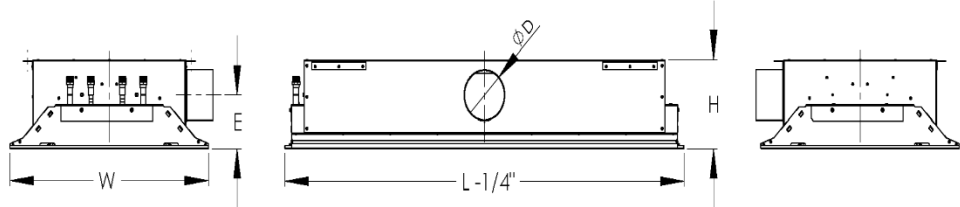

Right Coil Handing/
Pipes Right of Inlet

$W = 23\frac{3}{4}"$

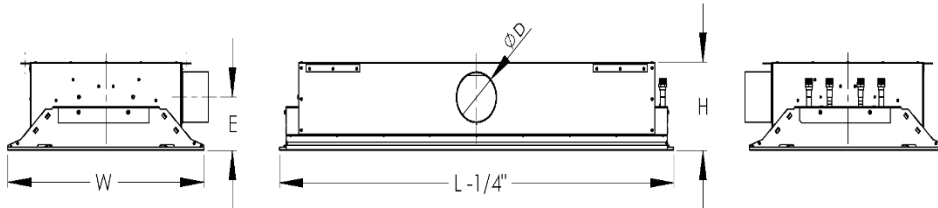

Top Inlet Casing is Universal

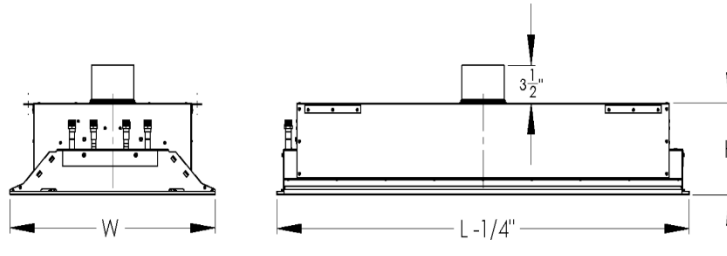

Fixed Bracket Mounting Locations

Beam Length	A (in)	B (in)	C (in)		
2'	6 1/2	-	-		
3'					
4'					
5'					
6'				19 3/8	10
7'				23 3/8	12
8'	27 3/8	14			

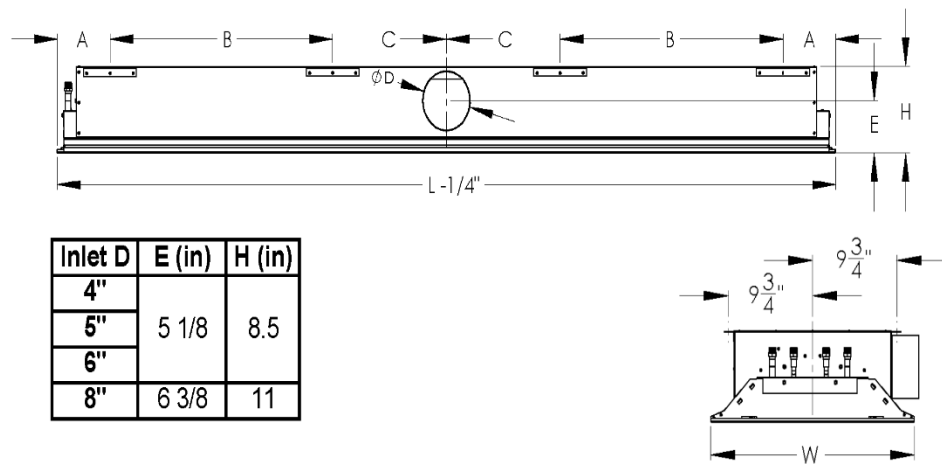

Inlet D	E (in)	H (in)
4"	5 1/8	8.5
5"		
6"		
8"	6 3/8	11

Ceiling Grid T-Bar Border Style Options

Standard (STD)

9/16" Tegular (TG1)

15/16" Tegular (TG2)

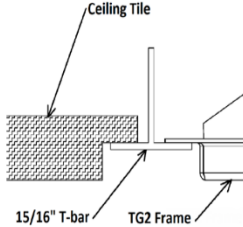
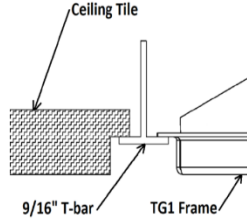
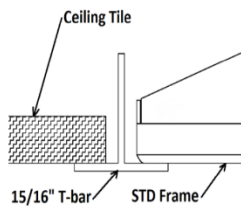

Exposed Mount Border

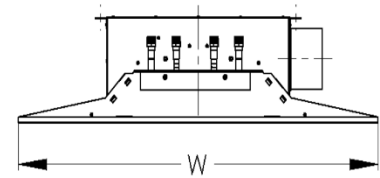

Length is Nominal L

$W = 36"$

CB-H24 STANDARD SPEC FEATURES

- 1-way or 2-way air distribution patterns
- 24-inch width
- 2 foot to 8 foot lengths, 1 foot increments
- Perforated induction air grill
- Left hand or right hand coil connections
- Side or top air inlet locations
- AHRI Standard 410 certified hydronic coil
- 2-pipe and 4-pipe coil configurations
- ½" MNPT water coil connections
- Coil drain valves
- Four types of induction ratio nozzles
- Commissioning port with room-side balancing
- Fixed heavy gauge mounting brackets
- 20GA Galv plenum construction sealed for protection against air leakage
- 20GA CRS casing construction
- Lay-in, tegular tee and exposed mounted border styles
- Reversible swing down hinged induced air grill
- Durable textured powder coat finish RAL9010 or RAL9016 in 30% gloss, custom colors available

OPTIONS AND ACCESSORIES

- ⅛" or ½" thick Armacell external insulation
- ½" sweet coil connections
- 12-inch, 18-inch, or 24-inch stainless steel braided hoses

CB-H24 NOMENCLATURE

